

RG8-EAS2		2ND STAGE REG PART LIST	
NO.	ITEM NO	DESCRIPTION	Q'TY
1	RP8-01	LONG MOUTHPIECE	1
2	RP8-02	NYLON TIE	1
3	RP8-03	MAIN HOUIING(H2O)	1
4	RP8-05	EXHAUST VALVE	2
5	RP8-06	DIAPHRAGM	1
6	RP8-07	DIAPHRAGM WASHER	1
7	RP8-08	ALU COVER RING	1
8	RP8-09Y	COVER BUTTON	1
9	RP8-10	NUT SCREW 5-40	1
10	RP8-11	STAINLESS SPACER	1
11	RP8-12	LEVER ARM	1
12	RP8-13	ADJUST TUBE	1
13	RP8-14	SPRING	1
14	RP8-15	POPPET	1
*15	RP8-16	LP SEAT	1
*16	RP8-17	15X1.5MM O-RING N70	1
17	RP8-18W	ORIFICE	1
*18	RP8-19	NBR O-RING N70	1
*19	RP8-20	NBR O-RING N70	1
20	RP8-28	ADJUST SCREW	1

\* : SERVICE KITS

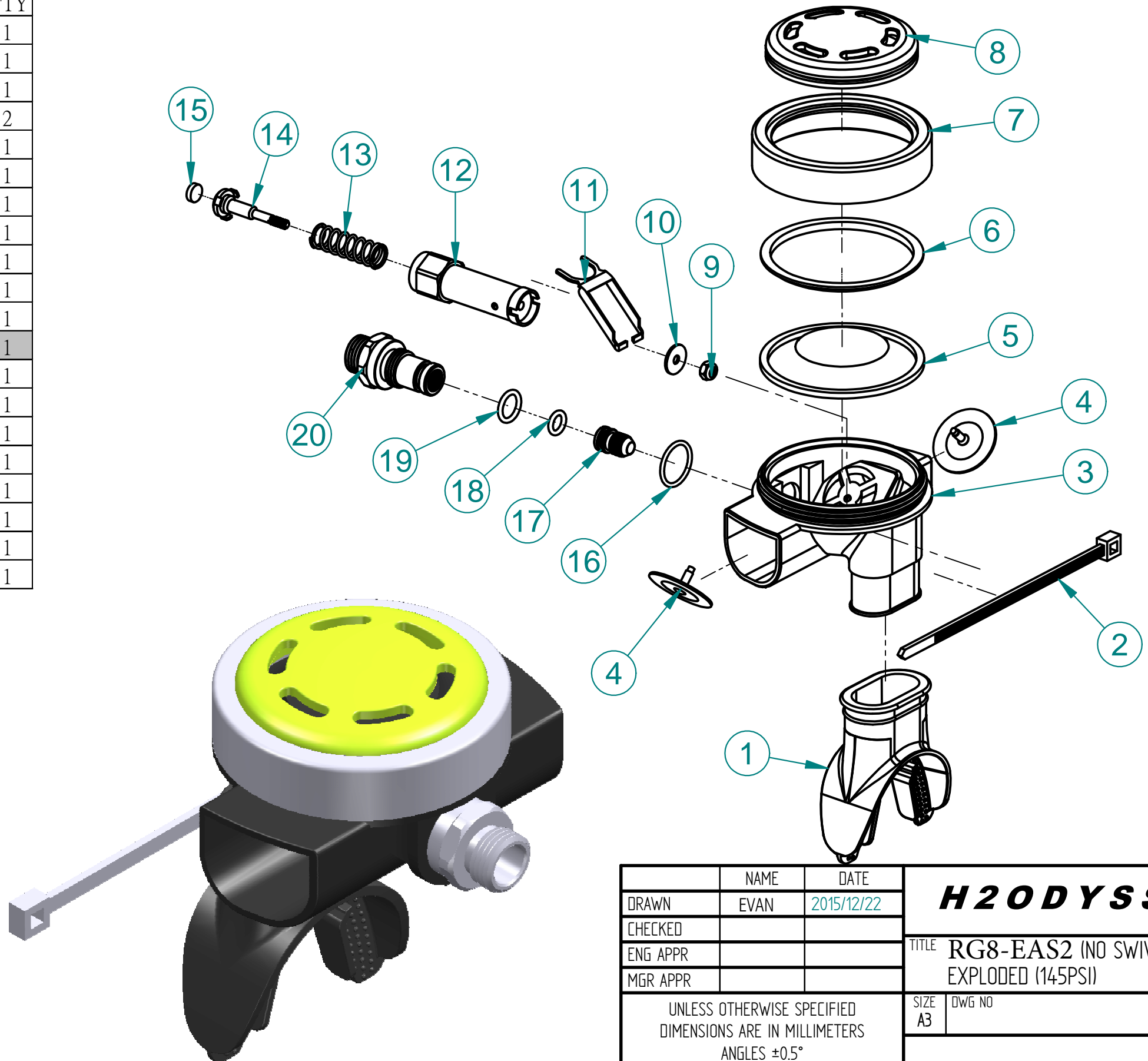

REVISION HISTORY			
REV	DESCRIPTION	DATE	APPROVED
A	DRAWING RELEASE	2006/10/27	
B	CHANGE ITEM NO 12 TO NEW PART	2009/09/14	
C	CORRECTED ITEM NO 3		

NAME	DATE	<b>H2ODYSSEY</b>	
DRAWN	EVAN	2015/12/22	
CHECKED			
ENG APPR			
MGR APPR			
UNLESS OTHERWISE SPECIFIED DIMENSIONS ARE IN MILLIMETERS ANGLES ±0.5° 2 PL ±0.05, 3 PL ±X.XXX		TITLE	RG8-EAS2 (NO SWIVEL) EXPLODED (145PSI)
SIZE	A3	DWG NO	REV C
SCALE:	WEIGHT:	SHEET 1 OF 1	